

TCXO

PT135M Series

PECL/LVDS

8PIN DIP PACKAGE

* PART NUMBERING GUIDE

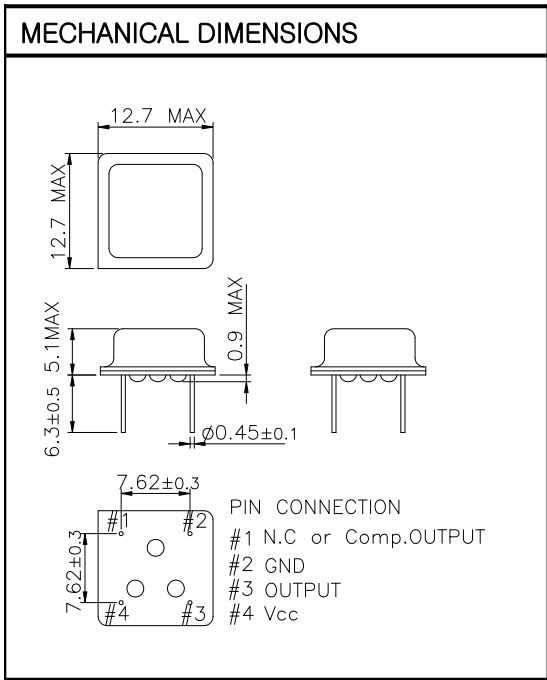
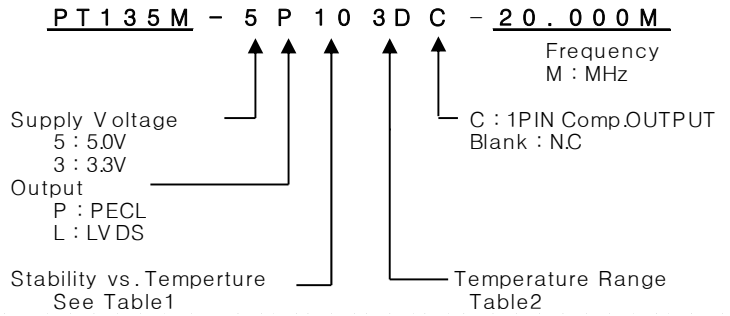

ELECTRICAL SPECIFICATION

Frequency range	8.00MHz to 1500.000MHz (All combinations for Frequency in the range and temp. stability can't be available, please contact factory.)	
Frequency Stability vs. Temperature vs. Supply Voltage vs. Load vs. Aging	±0.5 ppm to ±5.0ppm ±0.1 / ±0.3 ppm max / Vdd ± 5% ±0.2 ppm max /15pF ±10% ±1.0 ppm max/ year	
Temperature Range Operating Storage	See Table 2 -55°C to 125°C	
Supply Voltage	3.3V ± 5% 5.0V ± 5%	
Input Current 3.3 V , 5V	8.000MHz ~ 1500.000MHz 60mA max ~ 100mA max	
Output characteristics	pecl	lvds
Voh Logic "1"	Vdd-1.025v min.	1.43v typ.
Vol Logic "0"	Vdd-1.620v max.	1.10v typ.
Rise Time Tr	1.0 nsec max.	1.0 nsec max.
Fall Time Tf	1.0 nsec min.	1.0 nsec min.
Duty Cycle	50//50 ± 5%	50//50 ± 5%
Differential Output	Vod(Lvds)	330mV typ.
Offset Voltage	Vos(Lvds)	1.2V typ.
Phase Noise (typical) @20MHz	-80 dBc / Hz @ 10Hz -120 dBc / Hz @ 100Hz -135 dBc / Hz @ 1KHz -140 dBc / Hz @ 10KHz -145 dBc / Hz @100KHz	
Frequency Adjustment	±3ppm min by internal trimmer	

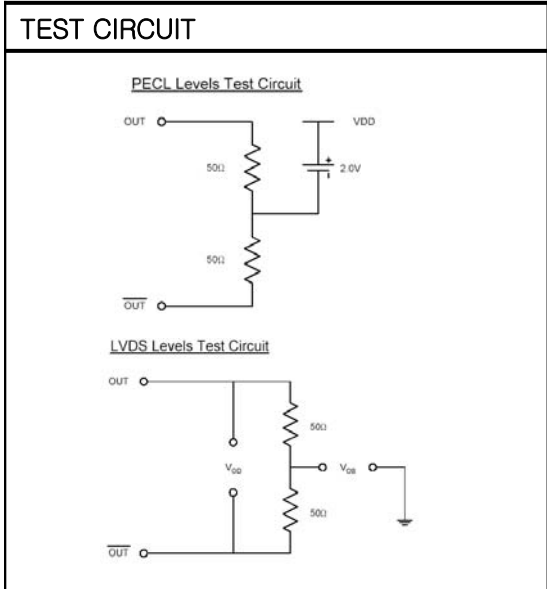
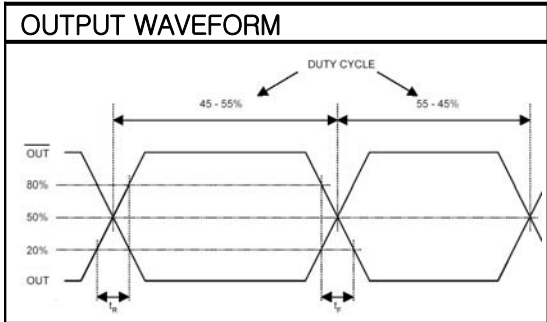

ENVIROMENTAL & MECHANICAL SPECIFICATION

Shock	MIL-STD-883C, Method 2002, Condition B
Vibration	MIL-STD-883C, Method 2007, Condition A
Solderability	MIL-STD-883C, Method 2003
Seal integrity	MIL-STD-883C, Method 1014, Condition C & A2
Marking	MIL-STD-202F, Method 215

TABLE1

Symbol	Stability
05	±0.5ppm
10	±1.0ppm
15	±1.5ppm
20	±2.0ppm
25	±2.5ppm
30	±3.0ppm
35	±3.5ppm
50	±5.0ppm

TABLE2

Symbol	Temp.	Symbol	Temp.
0	0°C	A	50°C
1	-10°C	B	60°C
2	-20°C	C	70°C
3	-30°C	D	75°C
4	-40°C	E	80°C
		F	85°C