

OSC

PO205M/PO207M Series
HCMOS/TTL
14PIN DIP PACKAGE

* PART NUMBERING GUIDE

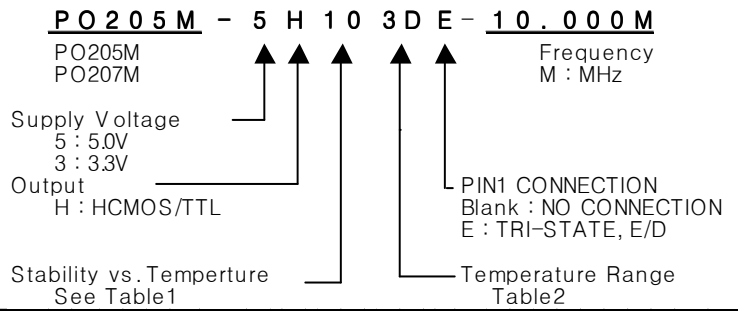

MECHANICAL DIMENSIONS

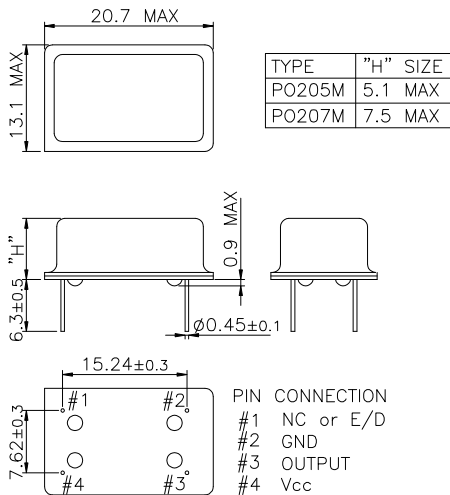

ELECTRICAL SPECIFICATION

Frequency range	1.000KHz to 800.000MHz All combination of Frequency range Vs. Package type might not be available ,please contact factory																		
Frequency Stability vs. Temperature vs. Aging	± 10 ppm to ±50ppm ±3.0 ppm max/ year																		
Temperature Range Operating Storage	See Table 2 -55°C to 105°C																		
Supply Voltage	3.3V ± 5% 5.0V ± 5%																		
Input Current 3.3 V , 5V	1.000KHz ~ 40.000MHz ~ 800.000MHz 15mA max ~ 30mA max ~ 100mA max																		
Output characteristics HCMOS / TTL	<table border="1"> <thead> <tr> <th></th> <th>HCMOS</th> <th>TTL</th> </tr> </thead> <tbody> <tr> <td>Logic "1"</td> <td>90% Vdd min</td> <td>2.4V min</td> </tr> <tr> <td>Logic "1"</td> <td>10% Vdd max</td> <td>0.4V min</td> </tr> <tr> <td>Load</td> <td>15pF</td> <td>10TTL</td> </tr> <tr> <td>Duty Cycle</td> <td>40/60</td> <td>40/60</td> </tr> <tr> <td>Rise & Fall</td> <td>10nS max</td> <td>10nS max</td> </tr> </tbody> </table>		HCMOS	TTL	Logic "1"	90% Vdd min	2.4V min	Logic "1"	10% Vdd max	0.4V min	Load	15pF	10TTL	Duty Cycle	40/60	40/60	Rise & Fall	10nS max	10nS max
	HCMOS	TTL																	
Logic "1"	90% Vdd min	2.4V min																	
Logic "1"	10% Vdd max	0.4V min																	
Load	15pF	10TTL																	
Duty Cycle	40/60	40/60																	
Rise & Fall	10nS max	10nS max																	
Pin 1 Tri-State Input Voltage	<table border="1"> <tbody> <tr> <td>No Connection</td> <td>Enable Output</td> </tr> <tr> <td>Vh ≥ 2.0 Vdc</td> <td>Enable Output</td> </tr> <tr> <td>Vi ≤ 0.8 Vdc</td> <td>Disable Output</td> </tr> </tbody> </table>	No Connection	Enable Output	Vh ≥ 2.0 Vdc	Enable Output	Vi ≤ 0.8 Vdc	Disable Output												
No Connection	Enable Output																		
Vh ≥ 2.0 Vdc	Enable Output																		
Vi ≤ 0.8 Vdc	Disable Output																		

OUTPUT WAVEFORM

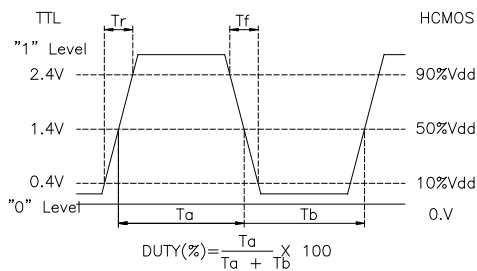

TEST CIRCUIT

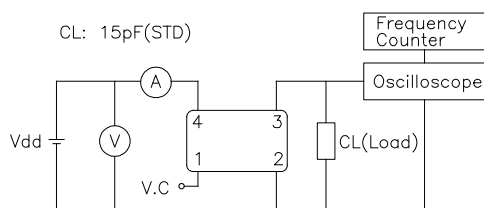

ENVIRONMENTAL & MECHANICAL SPECIFICATION

Shock	MIL-STD-883C, Method 2002, Condition B
Vibration	MIL-STD-883C, Method 2007, Condition A
Solderability	MIL-STD-883C, Method 2003
Seal integrity	MIL-STD-883C, Method 1014, Condition C & A2
Marking	MIL-STD-202F, Method 215

TABLE1

Symbol	Stability
10	± 10ppm
15	± 15ppm
20	± 20ppm
30	± 30ppm
50	± 50ppm
100	±100ppm

TABLE2

Symbol	Temp.	Symbol	Temp.
0	0°C	A	50°C
1	-10°C	B	60°C
2	-20°C	C	70°C
3	-30°C	D	75°C
4	-40°C	E	80°C
		F	85°C